

1-4 GHZ YIG OSCILLATORS

The OMNIYIG YOM SERIES provides YIG tuned oscillator designs electronically tuned in double octave bands. These units feature a novel coupling technique to provide maximum RF power output extended tuning frequency range and a lower, second harmonic and other spurious responses. The superb linearity of these oscillators is contributed by the ideal design of the magnetic circuit and the coupling technique used between the YIG sphere and the active element.

Available in two standard models covering the frequency ranges from 1.0 to 4.0 GHz. They are available in standard solid magnetic shell and in fast sweeping models. The electromagnetic circuit is driven from a current source and drivers are available that can be supplied as integral part to the oscillator. A typical driver control input of 0 to 10 volts will tune the oscillator the full frequency band.

All models meet applicable military specifications.

FEATURES

- **Miniature Packaging**
- **Superb Temperature Stability**
- **Excellent Tuning Linearity - 0.25%**
- **Extended Frequency Range**
- **All Other Spurious Signals 60 dB down**

APPLICATIONS

- **ECM Systems**
- **Spectrum Analyzers**
- **Sweep Generators**
- **Frequency Synthesizers**

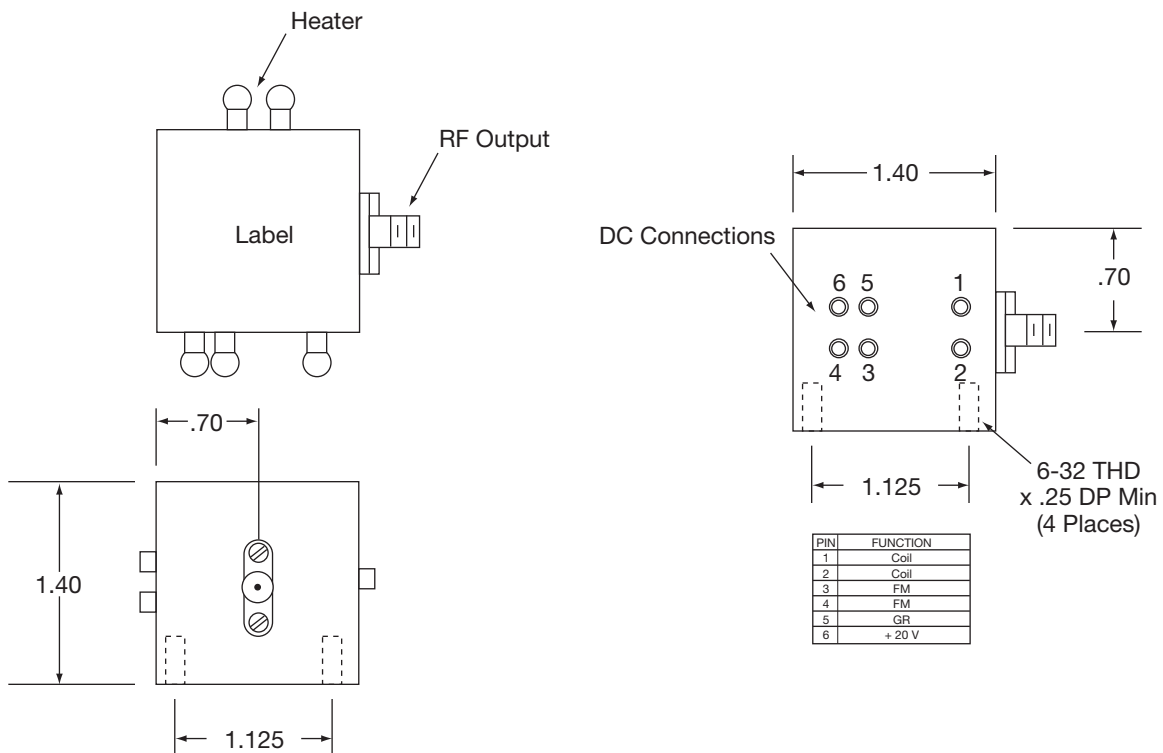

ELECTRICAL SPECIFICATIONS

Model Number	UNITS	YOM20	YOM40
Frequency Range	GHz	1.0 - 4.0	1.0 - 4.0
RF Power Output (Minimum)	mW	20	30
RF Power Output Variation	dB	±3	±2.5
Pulling figure (VSWR 2:1)	MHz	0.5	0.5
Second Harmonic	dBc	10	10
Other Spurious Signals	dBc	>60	>60
Frequency Drift (0° to +60°C)	MHz	±7	±7
Tuning Linearity	MHz	±0.5%	±0.5%
Hysteresis	MHz	4	4
Tuning Speed (full band w/in 6MHz final freq)	mSec	5	5
Tuning Sensitivity (Typical)	MHz/mA	13	13
Coil Resistance (Typical)	ohm	8	8
Coil Inductance (Typical)	mH	51	51

MECHANICAL SPECIFICATIONS, all model numbers

Dimensions	1.4" x 1.4" x 1.4"
Output RF Connector (female)	3 mm
DC Connector	Solder Pins
Weight (standard and fast sweeping models)	10 oz
Mounting (Tapped Holes x 4)	#6 - 32 (4 places)
Drawing (Yig Oscillator Only)	250-249-01

POWER SUPPLY REQUIREMENTS, all model numbers

Oscillator Supply	+15 Vdc @ 100 mA ¹
Heater Supply	20-30 Volts @ 50 mA, Steady State

NOTES:

- Other designs are available with +15 Volts oscillator requirement.
- YIG drivers for above designs are supplied in one integral package with oscillator.
Driver Control Voltage 0 - 10 Volts typical.
Driver Power Requirement ±15 Volts typical.
Other voltages are available.
- Other frequency ranges and double octave designs are available upon request.
- Higher power outputs are available.

