

4 to 18.0 GHz YIG-TUNED GaAs FET OSCILLATORS

Highly Reliable State-of-the-Art Thin-Film Technology

OMNIYIG's 4 to 18 GHz oscillators employ thin-film technology, coupled with GaAs FET transistors, and were designed using Computer Aided Design to provide highly reliable state-of-the-art performance.

10 and 30 mW and Higher RF Power Outputs

Two versions - 10 mW and 30 mW - are available, and each oscillator can be furnished in either a mini-cube or cylindrical package to meet your system's electrical and mechanical requirements, or other package.

Advanced Electrical Performance

Electronically tunable over the entire 4 to 18 GHz frequency range, these oscillators feature advanced coupling techniques to provide the highest power outputs available in the industry with the lowest second harmonic and spurious responses.

Superb Linearity - Better Than ± 12.5 MHz

OMNIYIG's proprietary magnetic circuit, and the coupling technique used between YIG sphere and active element, make the linearity of these oscillators better than ± 12.5 MHz.

With or Without Driver

Oscillators can be furnished stand-alone, or with integrated analog or digital drivers. A typical analog driver control input of 0 to 10 volts tunes the oscillator over the full frequency band. OMNIYIG's integrated 12-bit D to A converter allows you to step frequency in small increments using a TTL input.

Commercial or Military Use

Our standard oscillators are specified to operate from -20 to +65°C. However, all of OMNIYIG's products can be furnished to military specifications such as MIL-E-5400 class II/MIL-STD-883. OMNIYIG provides comprehensive environmental testing to insure compliance to these requirements.

Quality Assurance

Our Quality Assurance department maintains all documents in conformance to MIL-I-45208, and a calibration system to control and certify measurement accuracy in accordance with MIL-C-455662A.

OUTLINE DIMENSIONS

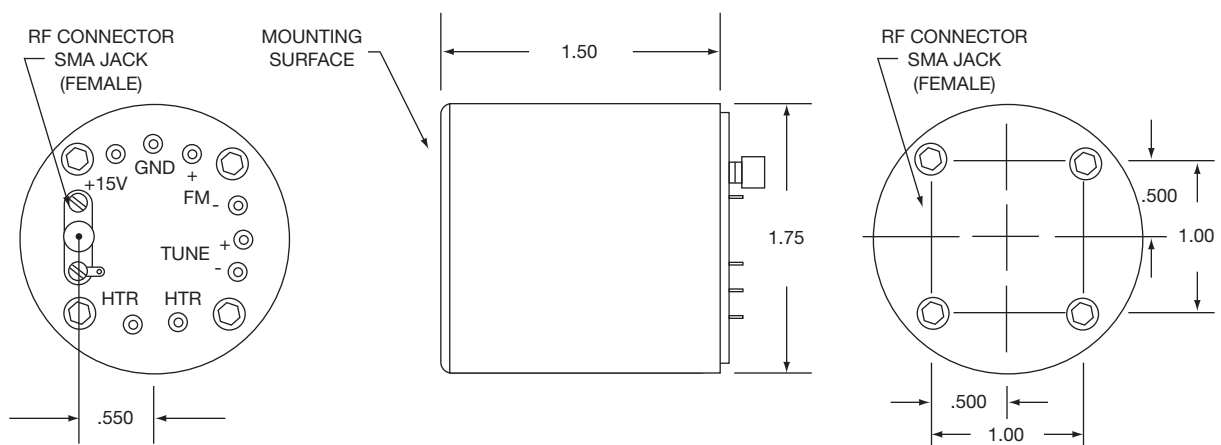

ELECTRICAL SPECIFICATIONS

Model Number	UNITS	YOM1513	YOM1514	YOM1515
Frequency Range	GHz	4.0 - 10.0	4.0 - 12.0	4.0 - 18.0
RF Power Output (Minimum) ⁵	mW	10	10	10
RF Power Output Variation	dB	±6	±6	±7
Pulling figure (VSWR 1.5:1)	MHz	±6	±6	±6
Second Harmonic	dBc	-12	-12	-12
Other Spurious Signals	dBc	>50	>50	>50
Frequency Drift (-20° to +65°C)	MHz	±10	±10	±15
Tuning Linearity	MHz	±12	±14	±40
Hysteresis	MHz	10	12	18
Tuning Speed (full band w/in 6MHz final freq)	mSec	10	10	20
Tuning Sensitivity (Typical)	MHz/mA	18	18	20
Coil Resistance (Typical)	ohm	10	10	10
Coil Inductance (Typical)	mH	100	100	100

MECHANICAL SPECIFICATIONS, all model numbers

Dimensions	1.75" x 1.5" cyl.
Output RF Connector (female or male)	3 mm
DC Connector	Solder Pins
Weight	20 oz
Mounting (Tapped Holes x 4)	#6 - 32
Drawing	250-014

POWER SUPPLY REQUIREMENTS, all model numbers

Oscillator Supply	+15 Vdc @ 300 mA Operating (typical)
Heater Supply	20 - 30 Vdc @ 50 mA, Steady State

NOTES:

1. Each oscillator will have test data sheet and the exact voltage will be indicated.
2. YIG drivers for the above models are supplied in one integral package with oscillator, if required:
DWG No. 82446 Analog Driver
DWG No. 82474 Digital Driver
3. Driver control voltage is typically 0–10 volts—for digital; 12-bit driver also available.
4. Other frequency ranges are available upon request.
5. Higher power outputs are also available.
6. Other package styles are available.